



Roller Fenders.

Characteristics

- ▶ Guiding system & energy absorption
- ▶ Typically maintenance free
- ▶ Multipurpose use
- ▶ No friction due to fender rotation

Applications

- ▶ Entrance to locks, dry docks and other narrow or exposed areas

ROLLER FENDER DIMENSIONS AND PERFORMANCE VALUES

Fender Type	A [mm]	B [mm]	C [mm]	∅ D [mm]	H [mm]	F [mm]	Energy [kJNm]	Reaction [kN]	Deflection [mm]	Pressure [bar]
RF 110 x 45	1,250	610	1,150	1,080	800	460	13	175	152	5.5
RF 130 x 50	1,530	740	1,400	1,320	950	510	22	200	230	3.5
RF 140 x 60	1,600	765	1,450	1,370	1,000	610	20	210	205	3.5
RF 175 x 70	2,050	975	1,850	1,750	1,250	690	37	345	225	4.8
RF 200 x 75	2,300	1,110	2,100	1,980	1,400	765	100	765	270	5.5
RF 250 x 100	3,000	1,425	2,700	2,550	1,800	895	170	1,000	345	5.5

Above mentioned sizes are indicative and may change during final design process

ROLLER FENDER DRAWING

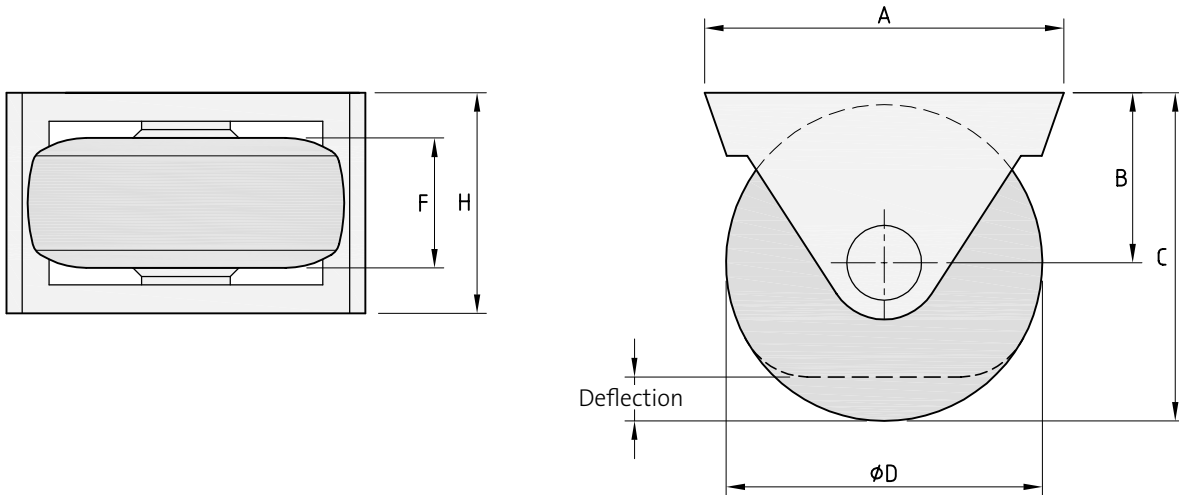

GENERIC PERFORMANCE CURVE ROLLER FENDERS

